

DETAILS DE RACCORDEMENT, VOIR FOLIO 2/3  
POITIONNEMENT BATTERIES DE DEMARRAGE, VOIR F3/3  
(FOR CONNECTION DETAILS, SEE SHEET 2/3  
ARRANGEMENT START BATTERY, SEE SHEET 3/3)

**VERSION 6 TURBOCHARGERS**

Ce plan vous est remis à titre indicatif et peut être révisé sans préavis.  
This drawing is for informational purposes only and maybe changed whitout notice.

Moteur Engine	Alternateur Generator	Masse (kg) Weight (lbs)		L1 (mm/inch)	L2 (mm/inch)	L3 C.D.G. / C.O.G. (mm/inch)		L4 (mm/inch)	L5 (mm/inch)	L6 (mm/inch)	L7 (mm/inch)	L8 (mm/inch)	L9 (mm/inch)	L10 (mm/inch)	L11 (mm/inch)	L12 (mm/inch)	L13 (mm/inch)	L14 (mm/inch)
		A vide/Dry	OdM/Wet			A vide/Dry	OdM/Wet											
20V4000 G23	LSA 51.2 VL95	16009/35295	16610/36619	4508/177.50	222/8.74	2355/92.73	2323/91.46	1200/47.24	1440/56.69	1870/73.62	1817/71.54	2278/89.69	695/27.36	795/31.32	911/35.87	1143/45.00	1196/47.09	857/33.74
20V4000 G43	LSA 53.1 M70	17183/37882	17794/39229	4574/180.01	311/12.25	2510/98.83	2477/97.50	1670/65.75	1920/75.59	2250/88.58	1917/75.45	2378/93.61	795/31.32	895/35.25	1011/39.78	1243/48.94	1296/51.02	891/35.08
20V4000 G23/63/83	LSA 53.1 M80	17343/38235	17954/39582	4574/180.01	311/12.25	2537/99.89	2503/98.53	1670/65.75	1920/75.59	2250/88.58	1917/75.45	2378/93.61	795/31.32	895/35.25	1011/39.78	1243/48.94	1296/51.02	891/35.08
20V4000 G63L	LSA 54 M75	18353/40461	18964/41808	4532/178.43	361/14.21	2622/103.24	2587/101.85	1670/65.75	1920/75.59	2250/88.58	1917/75.45	2378/93.61	795/31.32	895/35.25	1011/39.78	1243/48.94	1296/51.02	891/35.08
20V4000 G83L	LSA 54 M9	18990/41866	19601/43213	4532/178.43	361/14.21	2727/107.35	2689/105.88	1670/65.75	1920/75.59	2250/88.58	1917/75.45	2378/93.61	795/31.32	895/35.25	1011/39.78	1243/48.94	1296/51.02	891/35.08

Rev	Désignation de la modification (Description of change)	Statut (Status)	Date (Drawn by)	Visa (Checked by)	Date (Checked by)	Visa (Checked by)
F	MISE A JOUR COTE L1		27/10/14	BERNARD R		
E	AJOUT ALTERNATEUR LSA 512 VL95		21/08/14	NICOT M		
D	ALESAGE CONTRE BRIDE ECHAPPEMENT D1a246 DEVIENT D1a276		02/04/14	KERDRADON C.		
C	Mise à jour générale		30/04/13	G. ARCH		
B	Modification tableau: Evolution type alternateur		28/09/11	G. ARCH		
A	Création du document (First issue)		05/04/11	G. ARCH		

Matière (Material)	-	Format (Size)	A1
Revêtement (Coating)	-	Echelle (Scale)	1/15
Tolérance (Tolerance)	ISO 2768-mK	Folio (Sheet)	1/3
Désignation (Title)	GRUPE ELECTROGENE / GENERATING SET (MOTEUR / ENGINE MTU 20V4000-G03)	Masse (Weight)	Kg

**SDMO** 3-00-01-4478-01 Rev.: F

CE PLAN EST LA PROPRIETE DE SDMO. IL NE PEUT ETRE REPRODUIT, UTILISE OU COMMUNIQUE SANS SON AUTORISATION.  
THIS DRAWING IS UNDER PROPERTY OF THE COMPANY. IT CANNOT BE PRINTED, USED OR COMMUNICATED WITHOUT ITS AUTHORIZATION.

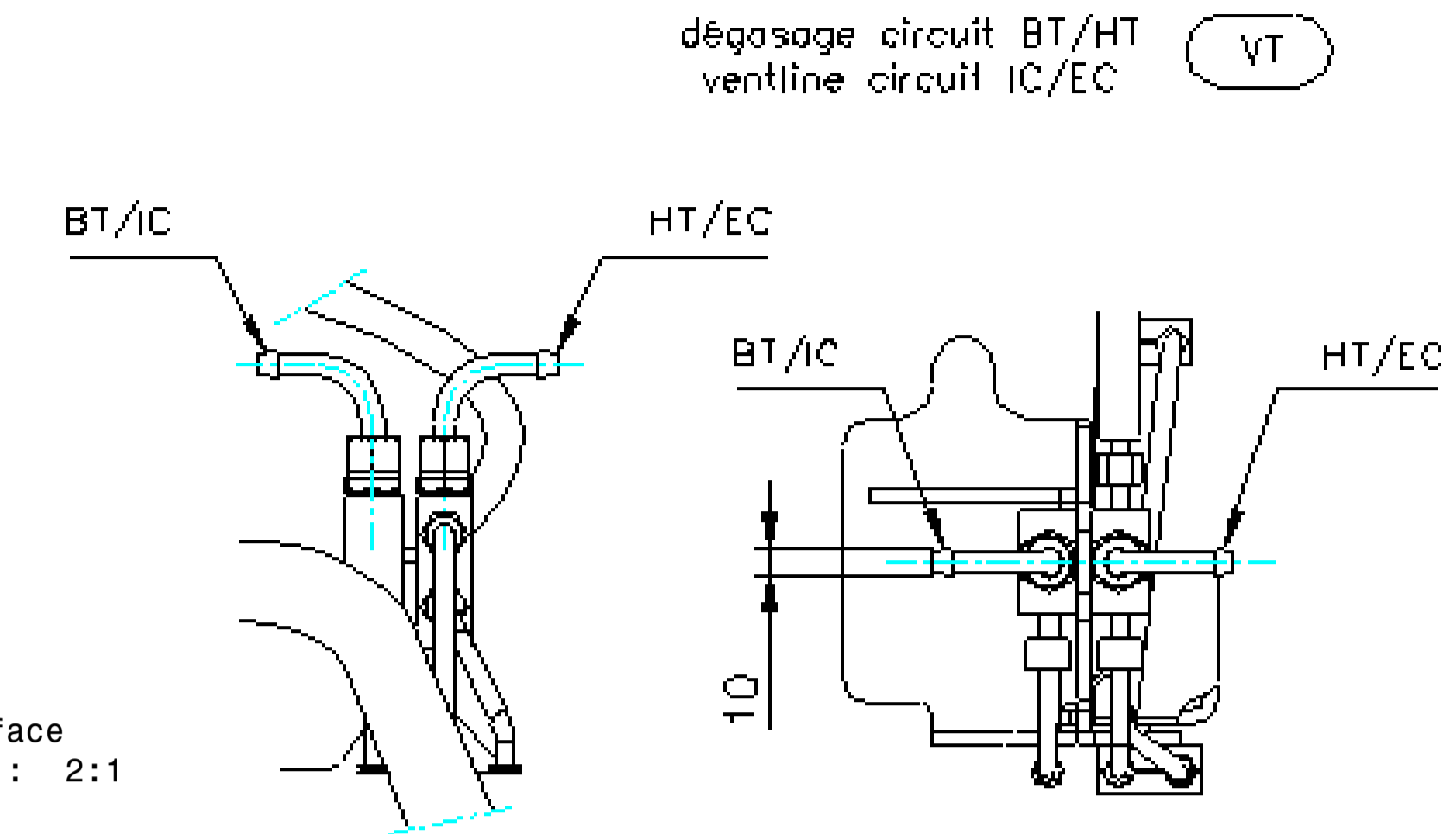
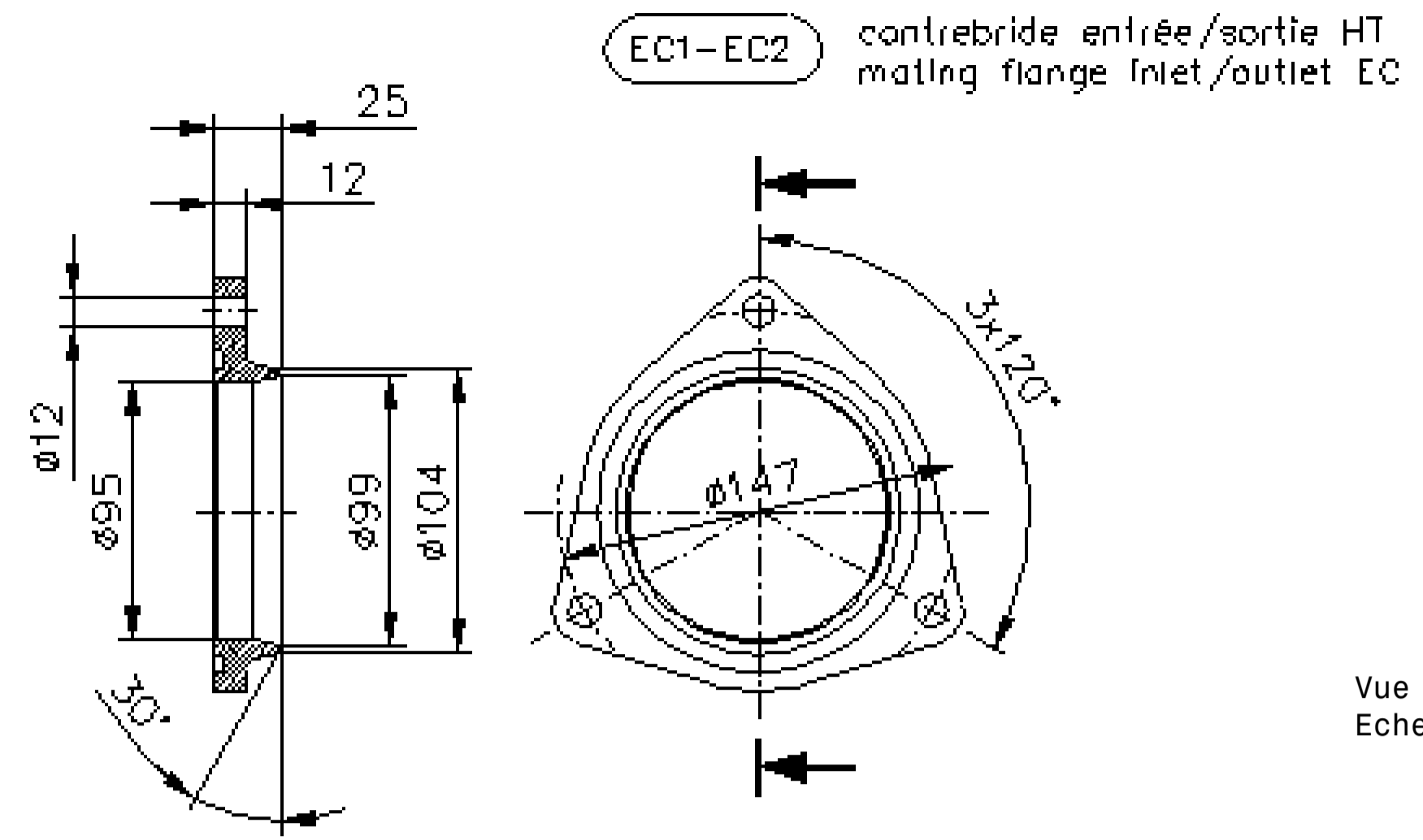
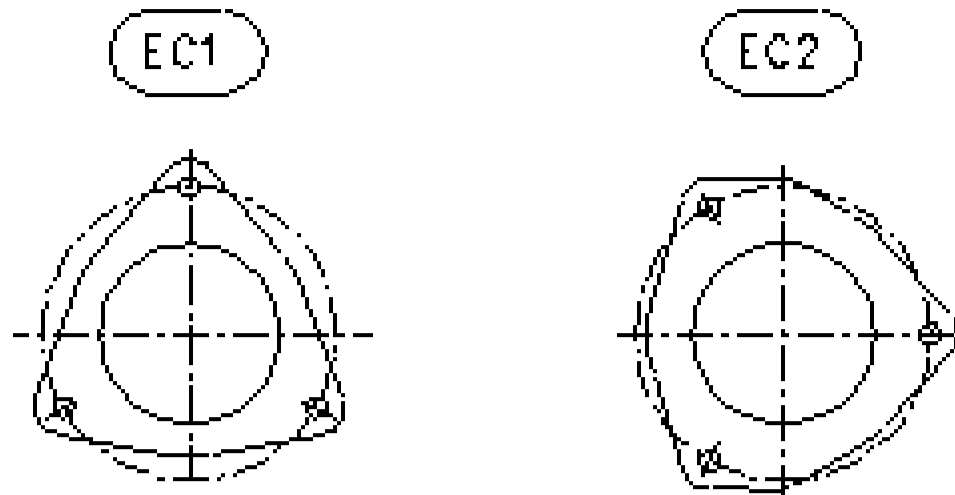

IC1-IC2 contrebride entrée/sortie BT  
mating flange inlet/outlet IC

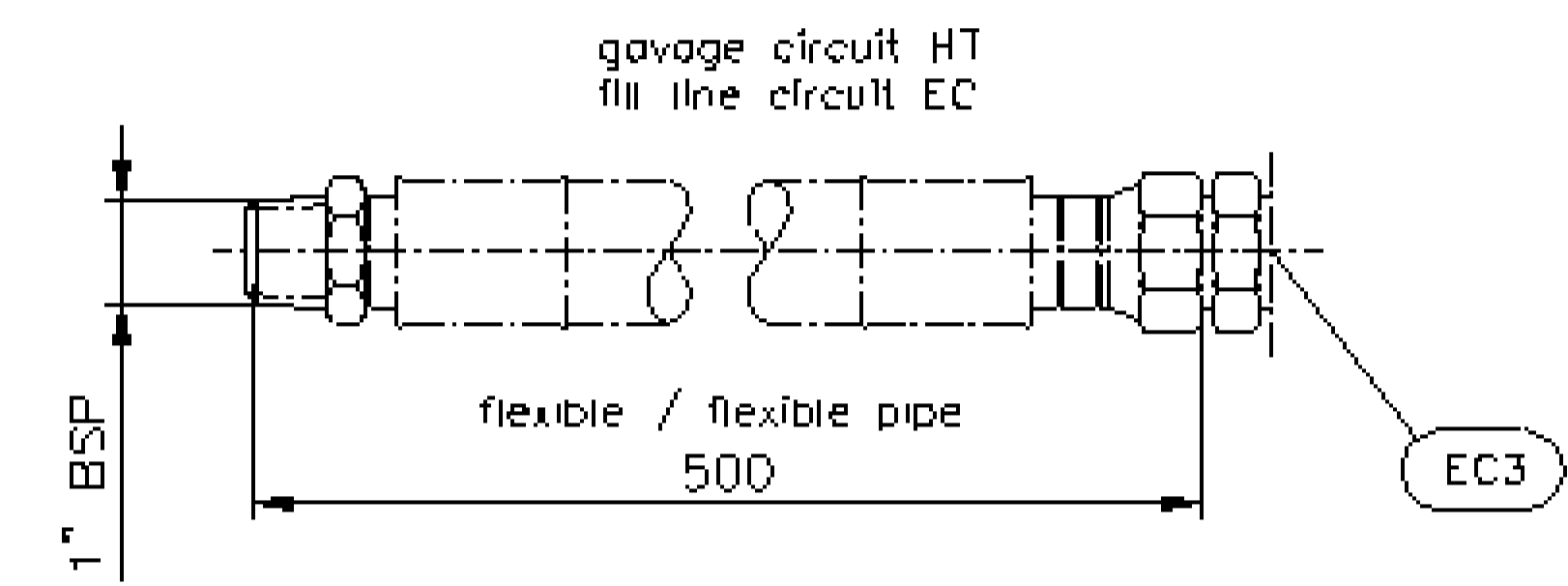
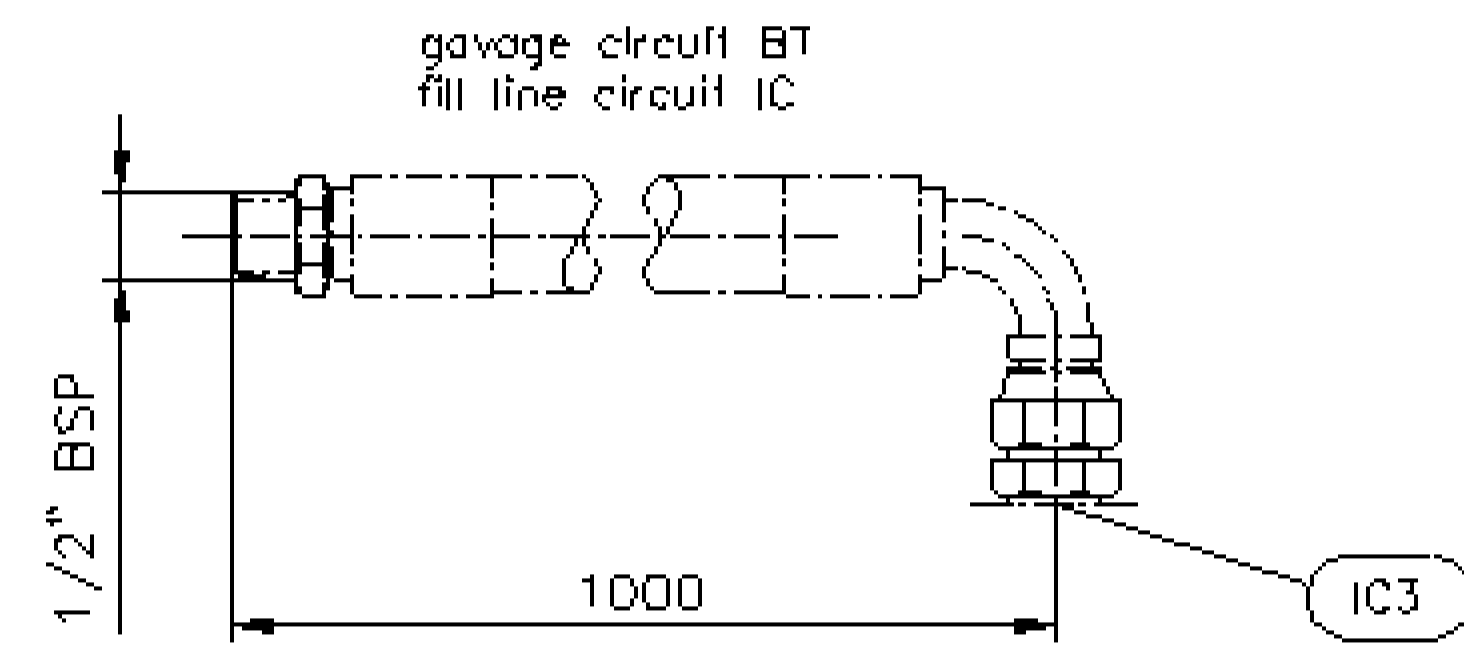
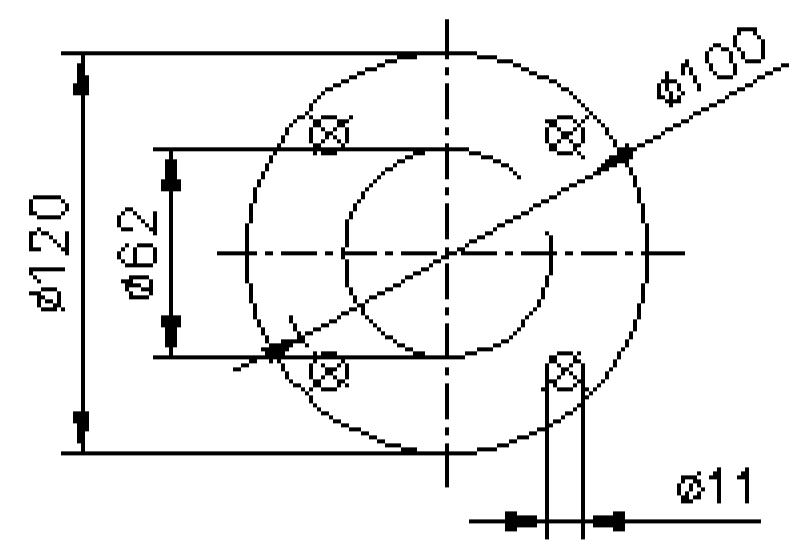

bride tournante sur compensateur  
perçage suivant DIN 86044

rotating flange on expansion bellows  
drill according to DIN 86044

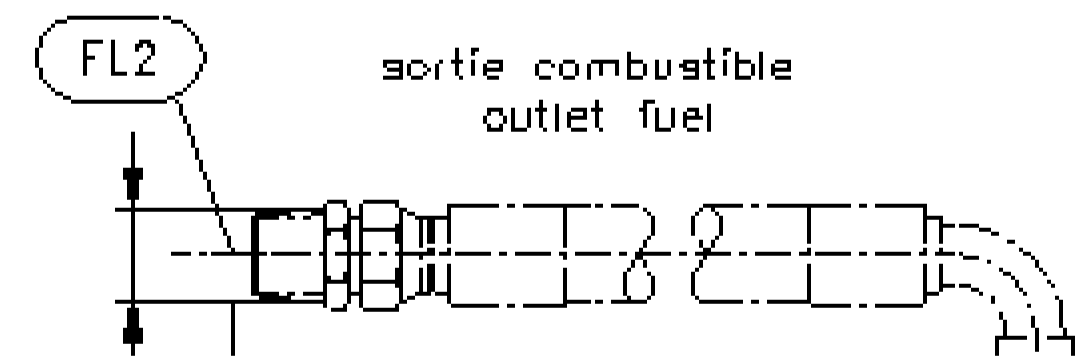
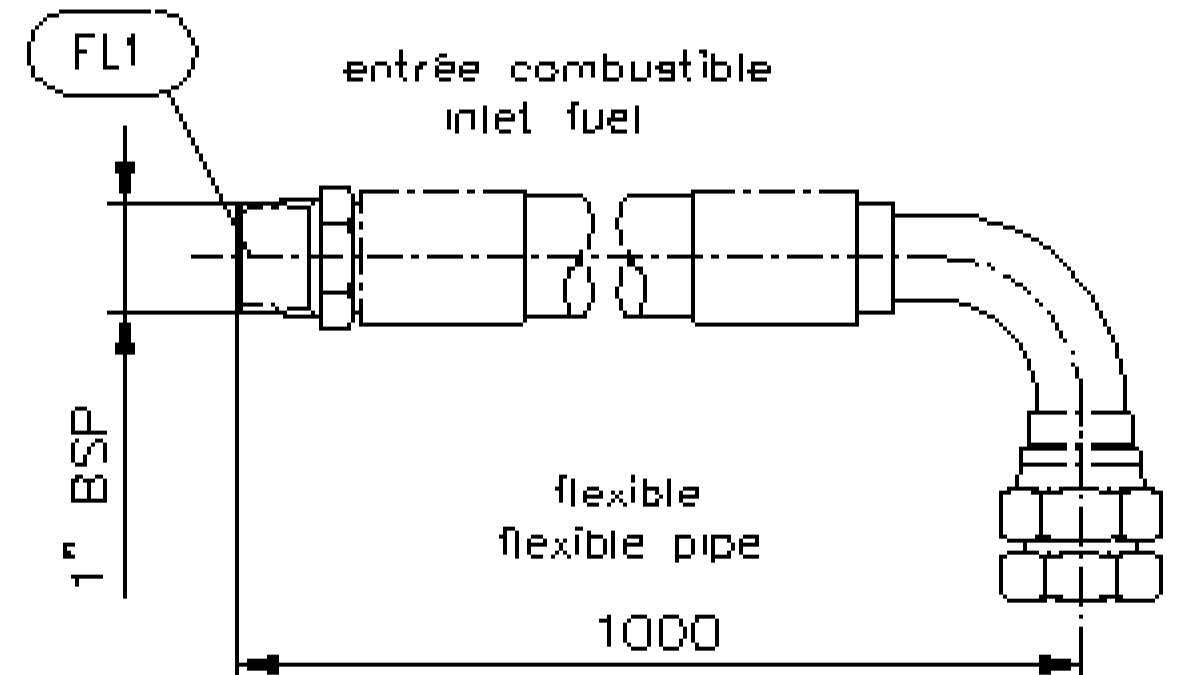
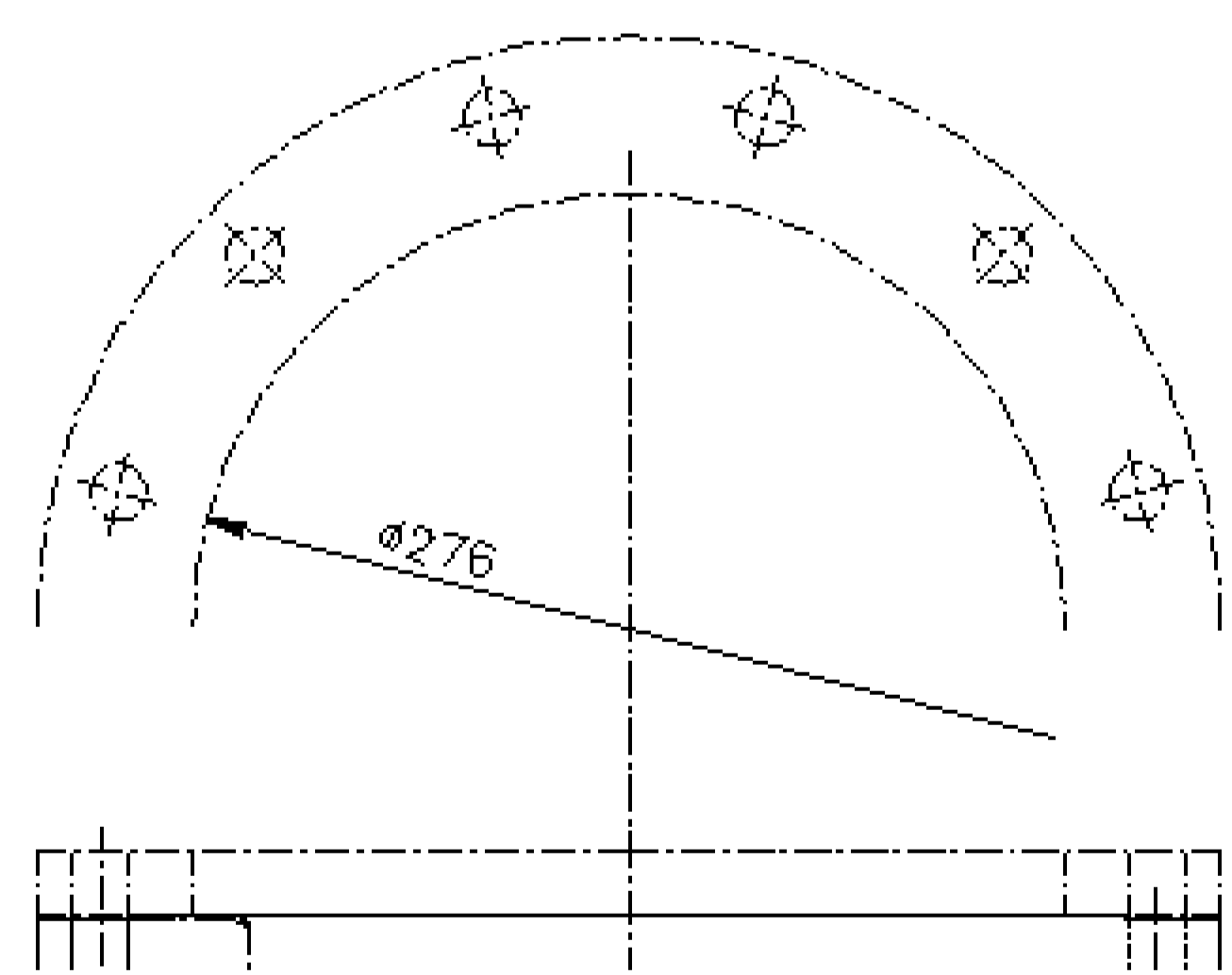

FOLIO 2/3  
DETAILS RACCORDEMENT  
(SHEET 2/3  
CONNECTING DETAILS)

Ce plan vous est remis à titre indicatif et peut être révisé sans préavis.  
This drawing is for informational purposes only and maybe changed whitout notice.

F	MISE A JOUR COTE L1	27/10/14	BERNARD R		
E	AJOUT ALTERNATEUR LSA 512 VL95	21/08/14	NICOT M		
D	ALESAGE CONTRE BRIDE ECHAPPEMENT Dia246 DEVIENT Dia276	02/04/14	KERDRAON C.		
C	Mise à jour générale	30/04/13	G. ARCH		
B	Modification tableau: Evolution type alternateur	28/09/11	G. ARCH		
A	Création du document (First issue)	05/04/11	G. ARCH		
Rev	Désignation de la modification (Description of change)	Statut (Status)	Date Dessiné par (Drawn by)	Visa Verificateur (Checked by)	Date Visa
Matière (Material)	-	Format (Size)	A1		
Revêtement (Coating)	-	Echelle (Scale)	1/4		
Tolérance (Tolerance)	ISO 2768-mK	Folio (Sheet)	2/3		
Désignation : (Title)	GROUPE ELECTROGENE / GENERATING SET (MOTEUR / ENGINE MTU 20V4000-G03)			Masse (Weight)	Kg
	3-00-01-4478-01	Rev. : F			



12 bis rue de la Villeneuve CS82848 29472 BREST Cedex2 Tel: 02 98 41 41 41 Fax: 02 98 41 63 07  
CE PLAN EST LA PROPRIETE DE SDMO. IL NE PEUT ETRE REPRODUIT, UTILISE OU COMMUNIQUE SANS SON AUTORISATION  
THIS DRAWING IS UNDER PROPERTY OF THE COMPANY. IT CANNOT BE PRINTED, USED OR COMMUNICATED WITHOUT ITS AUTHORIZATION

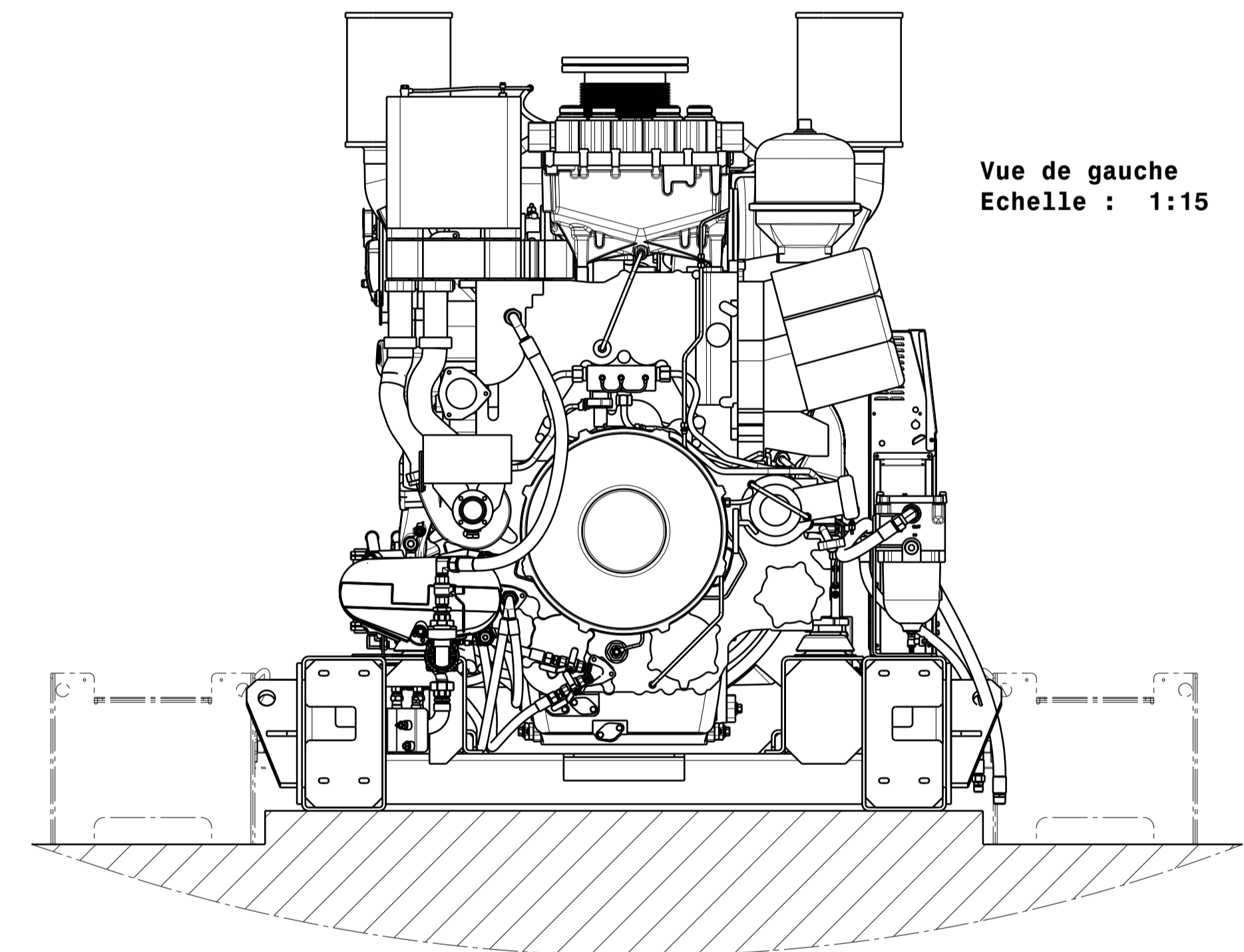
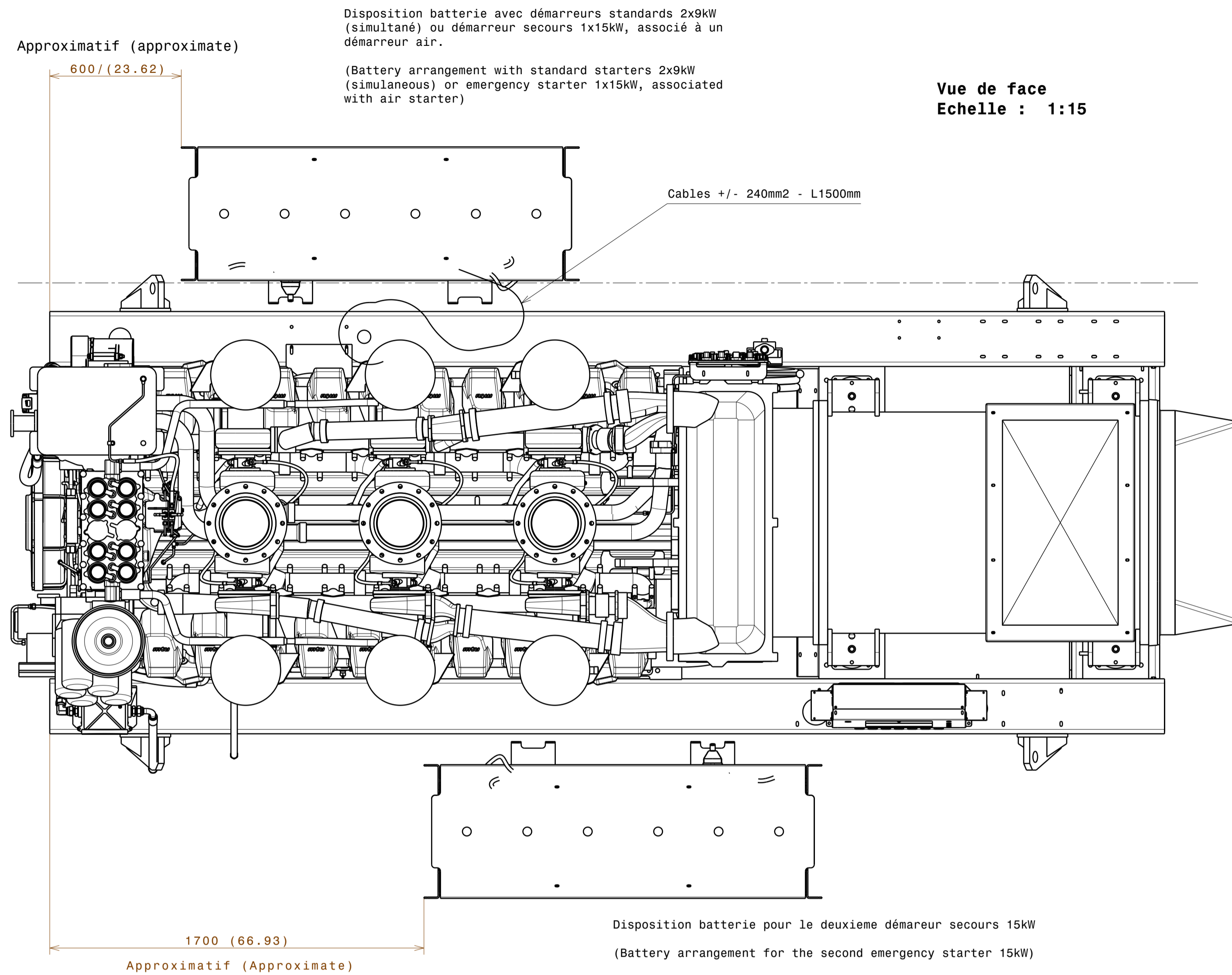

**Vue de face**  
Echelle : 1:15

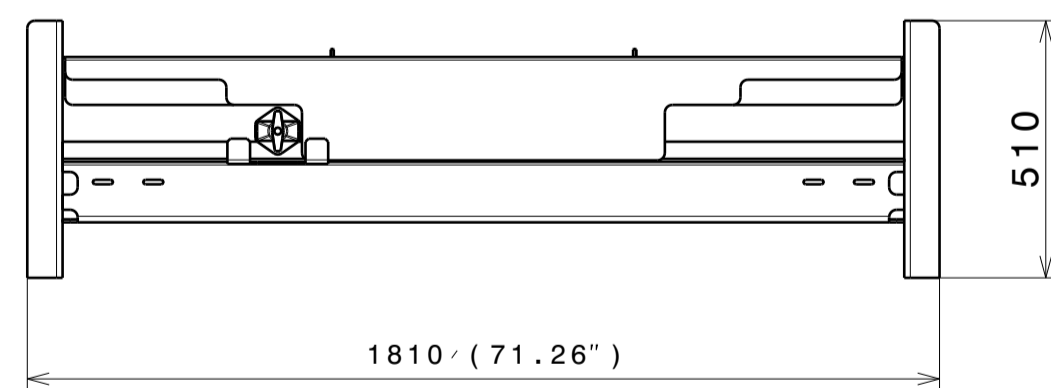

**Vue de gauche**  
Echelle : 1:15

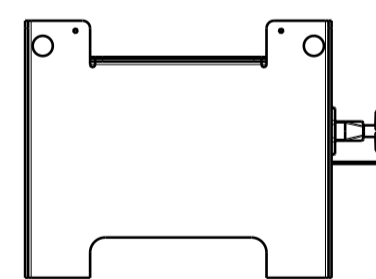

**Vue de dessus**  
Echelle : 1:15

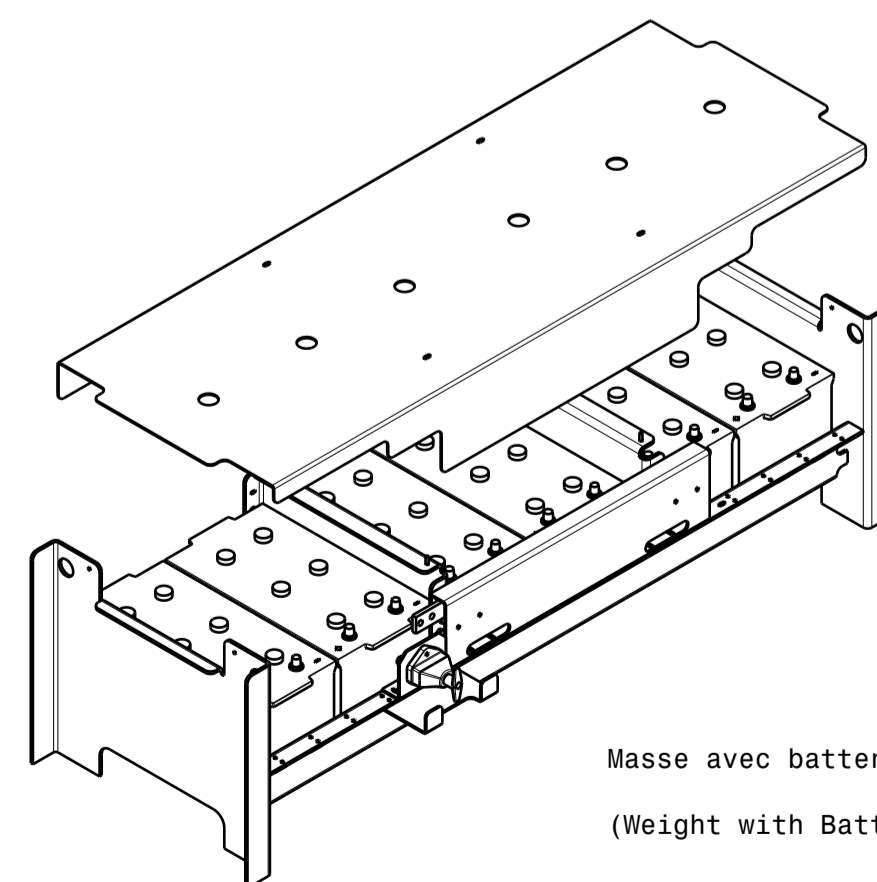
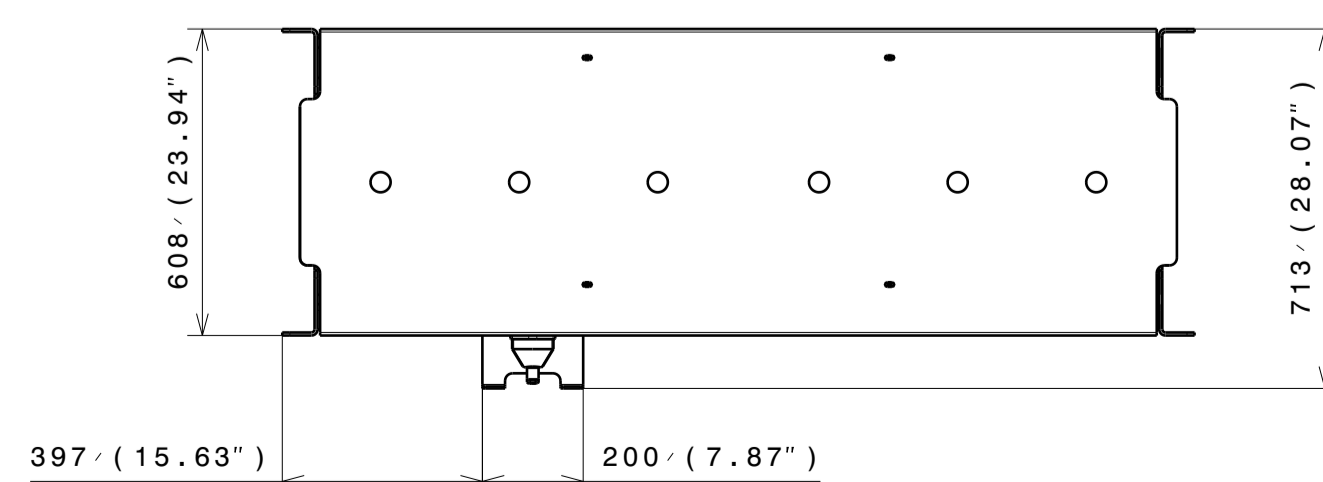

Masse avec batteries: 495kg  
(Weight with Battery: 495kg)

FOLIO 3/3  
POSITIONNEMENT BATTERIE DE DEMARRAGE (OPTION)  
(SHEET 3/3  
START BATTERY ARRANGEMENT (OPTIONAL))

F	MISE A JOUR COTE L1	27/10/14	BERNARD R		
E	AJOUT ALTERNATEUR LSA 512 VL95	21/08/14	NICOT M		
D	ALESAGE CONTRE BRIDE ECHAPPEMENT Dia246 DEVIENT Dia276	02/04/14	KERDRAON C.		
C	Mise à jour générale	30/04/13	G. ARCH		
B	Modification tableau: Evolution type alternateur	28/09/11	G. ARCH		
A	Création du document (First issue)	05/04/11	G. ARCH		
Rev	Désignation de la modification (Description of change)	Statut (Status)	Date (Date)	Visa (Checked by)	Date (Date)
Matière (Material)	-			Format (Size)	A1
Revêtement (Coating)	-			Echelle (Scale)	1/15
Tolérance (Tolerance)	ISO 2768-mK			Folio (Sheet)	3/3
Désignation : (Title)	GRUPE ELECTROGENE / GENERATING SET (MOTEUR / ENGINE MTU 20V4000-G03)			Masse (Weight)	Kg
	3-00-01-4478-01			Rev. : F	

Ce plan vous est remis à titre indicatif et peut être révisé sans préavis.  
This drawing is for informational purposes only and maybe changed without notice.



12 bis rue de la Villeneuve CS02848 29472 BREST Cedex2 Tél. 02 98 41 41 41 Fax 02 98 41 63 07  
CE PLAN EST LA PROPRIÉTÉ DE SDMO. IL NE PEUT ÊTRE REPRODUIT, UTILISÉ OU COMMUNIQUÉ SANS SON AUTORISATION  
THIS DRAWING IS UNDER PROPERTY OF THE COMPANY. IT CANNOT BE PRINTED, USED OR COMMUNICATED WITHOUT ITS AUTHORIZATION